

Developing a New Automatic Machine To Manipulate Sheet of Cardboard

Rodríguez Wilfrido
Centro de Ingeniería y Desarrollo Industrial
Mechatronics, Machinery Division
Pie de la Cuesta 702
Querétaro, CP76130
México
wilfrido@mecatronica.net

Vargas Emilio
Centro de Ingeniería y Desarrollo Industrial
Research and Postgraduate Unit
Pie de la Cuesta 702
Querétaro, CP76130
México
emilio@mecatronica.net

Abstract

This paper presents a new industrial automatic machine which is able to manipulate sheet of cardboard. The new machine is used to improve the production line quality of shampoos. A mechatronic design method is proposed as a part of the research and engineering interaction activities, but also the manufacture aspects and complex mechanical adjustments are considered. The machine developed consist of three basic subsystems: a) Sheet of Cardboard Table; b) Carousel of manipulators; and c) Transporter of boxes. Simulation and experimental results demonstrate the effectiveness of the machine designed. New potential applications for similar industrial production are discussed.

1. Introduction

Manipulation for industrial production lines is a research topic studied by many engineering disciplines, some of them are mechanics, robotics, mechatronics, or control theory. The design and construction of a manipulator system requires that material and human resource are well defined to join the movements required for the production. However, the automatic interaction between the machine and the production line is an important condition to permit a controlled actuation to get the industrial production expectative.

The cardboard is a kind of material widely used to pack many products. Exist a variety of machines that makes automatically boxes and put inside products. But, some characteristic productions for other products are not covered well. In this situation, the human resource often is required to manipulate with good precision, and high dexterous, but with the inconvenience to get mistakes and fatigue of human resource. The design and construction of a new machine is time-consuming, but is a way to plan better condition for human resource and increase productivity with the particular characteristic for the product considered.

The commercial machinery for industrial production is the result to integrate technologies and years of expertise to solve engineering production problems. The leader companies plan new products by benchmarking and project mechatronic products supported in some cases with applied research and improve the actual technologies. It is a fact as the leader companies get good commercial position and consumer preference when the industrial machinery is a guarantee to increase the productivity and the good business.

2. Machine Characteristics

The data from production line, space and energy requirements were analyzed to determine the distribution and characteristics of the machine. Table I shows the main specifications considered for the design.

TABLE I
MACHINE SPECIFICATIONS

Type	
Production ratio	28 sheet per minute
Power supply	440 VCA, Three phase
Pneumatic supply	8 bars
Controller	PLC Allen Bradley C-504
Monitoring display	Panel View 550
Security systems integrated	
Modular units for easy maintenance	
Dimensions: 5500 mm long, 2500 wide and 2500 mm height	
Material input: Boxes with shampoo bottles	
Sheet cardboard	
Material output: Boxes with sheet cardboard separating bottles of shampoo	

The bottles of shampoo are contained in a cardboard box as a part of the production line. This

box is provided to the machine by a transporter conveyor. By this way, a continuous line production of boxes with shampoo bottles inside is produced. The boxes are well separated to facilitate its carry and manipulation. Fig. 1 shows the transporter conveyor of boxes.



Figure 1. Boxes in the transporter conveyor

Separation between boxes is irregular; the machine has been designed to manipulate boxes with or without separation. The pull-force induced to the boxes from the transporter conveyor is an important parameter to avoid the possibility as the box can jump in the machine entrance.

3. Mechatronical Method Design

As a part of the plan to develop a new machine, a design method was used to reduce time and facilitate the interaction between the work's participants. A mechatronical method used for robotics design, and also for academic research project that is proposed by Vargas [1], [2] was used for this project. However, the method has not been used before for industrial projects, which are quite different for the quick and dynamic interaction oriented to reduce the project time. Fig. 2 shows the map concept of the method used.

After conceptualize the machine tasks, we organize three working groups, according with the subsystems as was divided the machine at the beginning of the project: a) Sheet of Cardboard Table; b) Carousel of manipulators; and c) Transporter of boxes.

The method consists, first of all, in generating mathematical models which describe the behavior of the mechanical, electro-mechanical or pneumatic-mechanical systems.

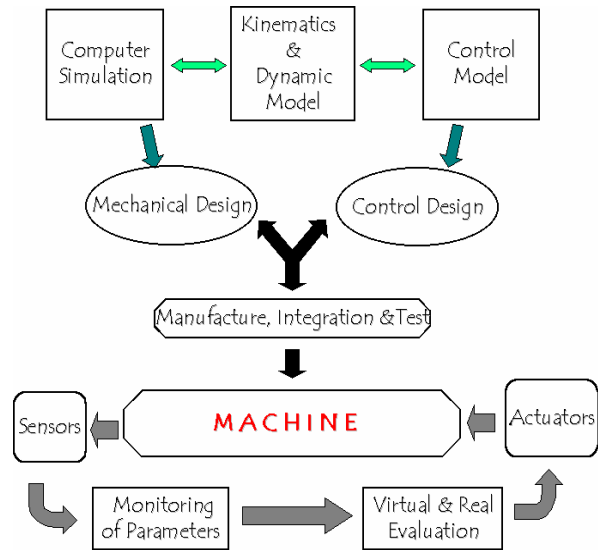

Figure 2. Conceptual map of the method

The kinematics and dynamics models are well defined to evaluate by simulation the parameters for each system as can be used in the real machine. The dynamic model permits us to simulate the necessary forces to move the mechanisms for the machine, but also to construct the control model or its conceptualization. After validation by simulation the models and the virtual design, the next step consist to do the mechanical design of the systems. In this time, it is assumed that also control design can be made, by this way the fundamental elements are defined and others can be bought. Usually, during the manufacture process the design parameters are changed, some of them depend of the material properties, and other factors for the final dimension in the elements. Any case, it is recommended to improve the models with these changes and simulate again the designs. As well known, there are also changes when the systems are integrated. New modifications were implemented to pass the production tests. After to get a machine integrated as can make a good quality production, the method ends by comparing the real and virtual systems.

The main idea is modify and improve the models used to design the machine, and get a better understand of the behaviour of the systems.

4. Systems Design

a) Sheet of Cardboard Table.

The function of the sheet of cardboard table is to provide automatically sheet of cardboard previously bended to the carousel of manipulators. The table is designed to facilitate the entrance of material by the

operator. The operator can review the packets of sheet of cardboard, and put the packets on the table. We consider use the gravity force to transport the sheet of cardboard, and get the manipulation of each sheet by a mechanism based on linear pneumatics actuators and vacuum catcher. The kinematics model for the mechanism was simulated to evaluate the commercial elements as can be used to get the manipulation designed. Fig.3 shows the manipulation in the sheet of cardboard table. 1) Pneumatic cylinder to pivot the vacuum catcher; 2) Pneumatic cylinder to bend the sheet ; 3) Pneumatic cylinder to get in touch the vacuum catcher with the sheet of cardboard; 4) Vacuum catcher to move the sheet of cardboard; 5) Sheet of cardboard; 6) Steel bar to bend the sheet; 7) Base to support the sheet bended.

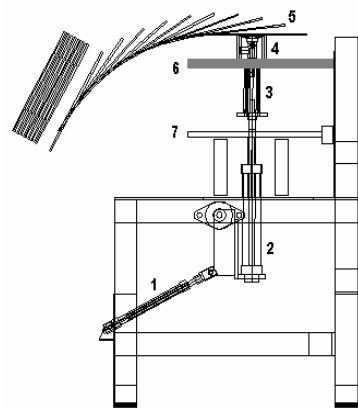

a) Moving a sheet of cardboard

Sheet of cardboard bended

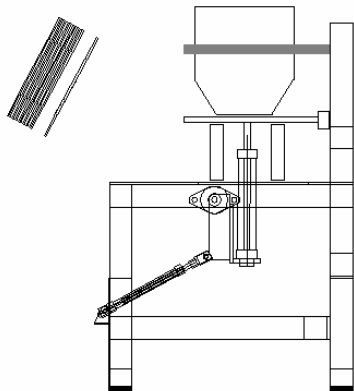

b) Bending a sheet of cardboard

Figure 3. Manipulation in the sheet of cardboard table

b) Carousel of manipulators.

The function of the carousel of manipulators is to move the sheet of cardboard from the sheet cardboard table to the transporter of boxes. To do that, the carousel has six manipulators distributed around its

perimeter. Each manipulator takes one sheet of cardboard which was previously bended, and insert it in a box of cardboard. During the insertion, the carousel and the transporter box don't stop its moves. So, a mechanical train gear is used to synchronize the moves and get the same lineal speed for both systems. A three-phase AC motor of 3 Horsepower is used to move the carousel and the transporter of boxes.

The carousel rotates around a vertical axe, which is impulsed for a train gear, this train gear also impulse an horizontal axe to move the transporter. The forces to move the six pneumatic manipulators it is transferred by a hole-pin chain, which is also pushed by a sprocket placed in the shaft of the train gear.

Same distance of each manipulator is considered in the carousel configuration. So, by this configuration, when a pneumatic manipulator takes a blade sheet cardboard (2), other pneumatic manipulator puts a blade sheet cardboard inside of the a cardboard box (6). The carousel was designed with the aim subject to place in continuous move the sheet of cardboard in concordance with the moves of the boxes. One of the problems was to synchronize the carousel and the transporter of boxes moves, we solve this situation using a hole pin chain in both systems.

Fig. 4 shows a layout of the machine. 1) Inclined sheet of cardboard table; 2) Separator former; 3)Carousel; 4) Pneumatic manipulator; 5) Transport conveyor of boxes (input); 6) Transporter of boxes; 7) Area for non-conformed product; 8) Transport conveyor of boxes (output); 9) Controller.

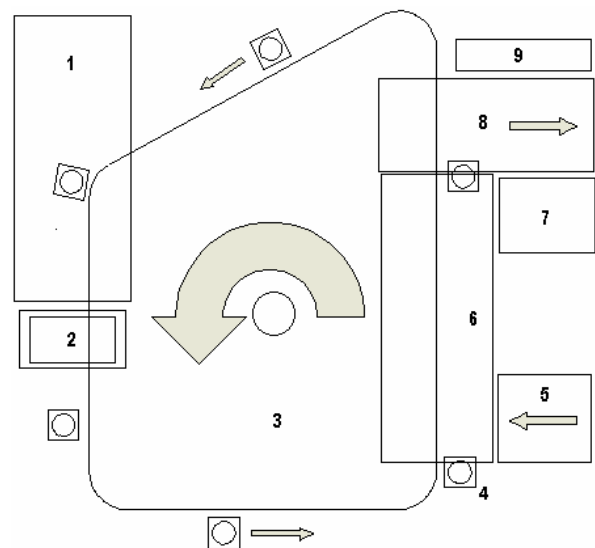

Figure 4. Layout of the Machine

c) Transporter of boxes.

The function of this system is to transport the boxes from the entrance transport conveyor to the exit transport conveyor. This system is designed to move the boxes with the same lineal speed of the manipulators. A box is received for steel cylinders in the entrance area of this system, then a push-bucket is used to move the box, and after a sheet of cardboard is introduced to the box. Finally, the box rotates 90 degrees before to be moved to the exit area. Inspection of each move is required in order to ensure the correct production. However, when the manipulator doesn't make a good position for the sheet of cardboard in the box, the product is refused. A pneumatic lineal actuator is used to move product refused to the area for non-conformed product, on this situation human assistance is considered to check the product and correct it.

5. Communication & Control System

The system communication is essential to send and receive the machine conditions for the control system. We apply an industrial field bus network to transmit information and reduce the number of electrical cables for the sensors and actuators. Fig. 5 shows the network architecture used to control the machine with a Programmable Logic Controller (PLC) according with the state of the sensors. 1) PLC; 2) Commuter; 3) Panelview; 4) Communication module; 5) Actuator module; 6) Sensor module.

A Panel View 550 is utilized to display the machine states and visualize the menus implemented to check the statistical parameters for the production online. Table II shows a relationship of sensors and actuators used in the main systems of the machine.

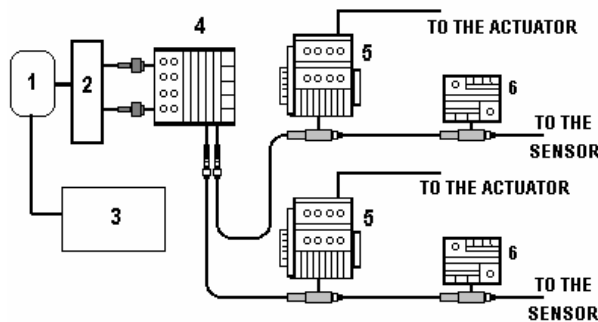

Fig.5 Network arrangement for the control

TABLE II
 SENSORS AND ACTUATORS IN THE SYSTEMS

Actuators	No. Sensors	No.
Sheet of cardboard Table	8	4
Carousel of manipulators	27	12
Transporter of boxes	8	4
Security system	8	0

The control unit drives 20 actuators, in concordance with a control program and the information processed from the 51 sensors used for the machine. A statistical data about the production is generated online, and the operator can switch from automatic control to manual control. By this way, in the case of any problem in the production, the operator can easily move the machine. Also the manual control is planned to facilitate maintenance tasks and emergency actuation.

6. Results

There are two important parameters considered to evaluate the production during the test of the machine: Stops in the machine, and Number of non-conformed product. The statistical production data reports as 1 of each 1680 boxes can stop the machine for defects in the box of cardboard. In this case, the operator takes 2 minutes to re-establish the production. So, a projection time induced for this defects in the box for a journey labor of 7 hours are around 15 minutes. Other cause to stop the machine is a non-well bended sheet of cardboard. The statistical production data obtained shows a frequency of 63 stops in the machine in a journey labor, the time medium calculated for all this stops is around 20 minutes. Test production in the machine shows a time-production efficiency of 0.9 %.

The number of non-conformed product as we got automatically in a journey labor was 18, but after a visual inspection of the operator only 2 boxes shows a bad insertion of the sheet into the box, the other boxes was refused for the close tolerance of the sensor used to inspect this situation. Fig. 6 shows the machine to manipulate sheet of cardboard.

The maximum speed range of the machine for a good production is between 24 to 28 sheets of cardboard per minute. The total weight of the machine is 1800 Kgs.



Figure 6. Machine to manipulate sheet of cardboard.

7. Conclusions

A new industrial automatic machine, which is able to manipulate sheet of cardboard, was shown. The box of cardboard is manipulated and changes its orientation 90 degrees with the respect to the line direction of the conveyor belt and the sheet of cardboard is inserted into the box without stop the move of the box, continually. The advantages to design an industrial automatic machine to manipulate sheet of cardboard with particular characteristics were the following:

- Get experience to apply a mechatronic method for design industrial machinery.
- Integrate a team to make engineering and manufacturing work with the intention to cover the production expectative.
- Get expertise to manipulate in high-speed production the sheet of cardboard.
- Develop an own knowledge to integrate technologies for the design of industrial machinery.

The different tests done in the machine shows that the manipulation of the boxes and sheet cardboard are according with the expectative for industrial production in the shampoo line. Range sense for position sensors were studied and redefined to avoid non-conformed product. We belief that exist other potential application for the machine, for example: oil bottles production, bear bottles production, and so on.

Cause the machine is able to accommodate between bottles a sheet of cardboard that reduce the possibility to slip the product.

8. Acknowledgment

The authors like to thank all members of Centro de Ingeniería y Desarrollo Industrial for its help and support for the project No. 40936. Especial thanks to Rodolfo Coria, Head of Mechatronics Machinery Division. We thank to Jorge Hurtado, and Jorge Vargas to contract us, and their trust and patience during the design and test of the machine.

References

- [1] Vargas E., Reynoso G., Villarreal L, Mier R., "Diseño de un Robot Industrial para Aplicaciones de Limpieza en Subestaciones Eléctricas", *Memorias del 3er. Congreso Mexicano de Robótica*, Asociación Mexicana de Robótica. Septiembre 2001, Querétaro.
- [2] Gorrostieta E., y Vargas E. ,“Free Locomotion for Six Legged Robot”, 3er. *WSEAS International Conference on Signal Processing, Robotics and Automation*, ISPRA 2004, ISBN 960-8052-95-5, February 13-15, Salzburg, Austria. 2004.